

MACHINE DESCRIPTION

The RC65 filler returns a compact and well distributed soil: mainly suited for the filling of trays, pots and containers in general which must then be sown.

The soil is distributed by a 4-blade rotor with adjustable speed: this is used to easily adjust the final density of the soil in the cells.

The machine is robust, simple to use and easy to maintain. Particularly suitable for production lines that require the changeover of the filling material during operation: the emptying of the hopper and the complete cleaning of the components, in fact, are quick and simple to perform, thus saving operator time.

It is equipped with cranks for quick self-centring adjustment of the containers. Excess soil recovery belt available as an accessory.

Thanks to the feeding belt system, the RC65 filler can be used both as a stand-alone machine and in a working line.

p. 64-65

MAIN ACCESSORIES

47 48 49 50 51 52 53 56 57 58 59

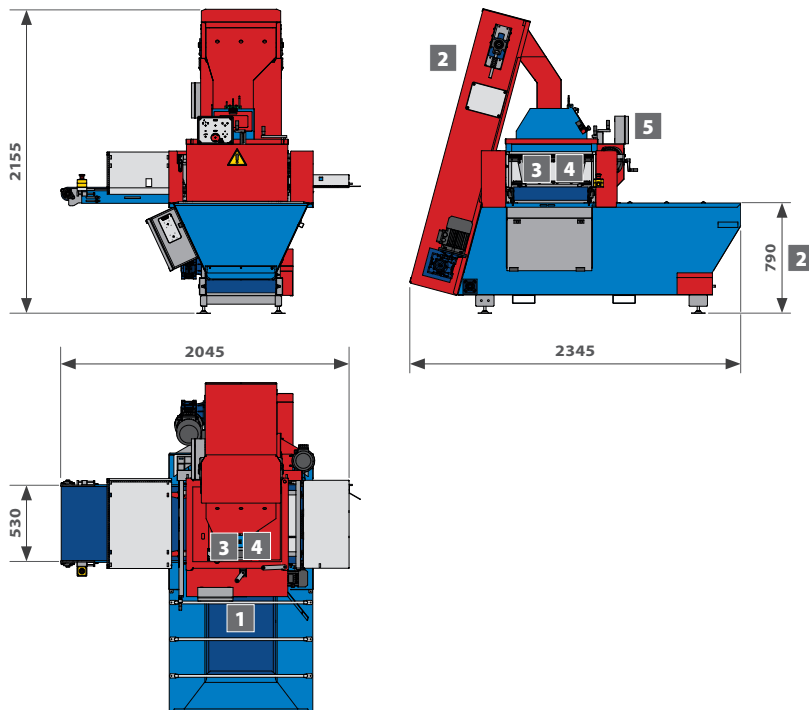

TECHNICAL SPECIFICATIONS

- 1 Hopper capacity (standard): 700 litres. Conveyor belt on hopper's bottom with rollers.
 - Quick self-centring guide adjustment system.
- 2 Easily usable soil loading height.
 - Double chain soil elevator.
- 3 Soil distribution with 4-blade longitudinal rotor, electronically controlled.
 - Double auger spillway with motorized brush for tray cleaning.
- 4 Double auger spillway with motorized brush for tray cleaning.
 - Available in left and right version.
- 5 Electric control panel start-stop, emergency and limit switch.

TECHNICAL DATA

	M.U.	RC65	RC65 A	RC65 E
HOURLY PRODUCTION (max)	trays/hour	600	600	600
HOPPER CAPACITY (standard)	l	700 (*)	700 (*)	700 (*)
TRAYS DIMENSIONS (max)	mm	600x400	750x400	750x500
TRAYS HEIGHT (max)	mm	200	200	200
INSTALLED POWER	kW	4,5	4,5	4,5
WEIGHT	kg	585	585	585

(*)= hopper capacity 550 liters if combined with recovery excess soil belt (ACCESSORY)



RC65
TRAY FILLER - up to 600 trays/hour



MAIN ACCESSORIES

TRAY FILLERS

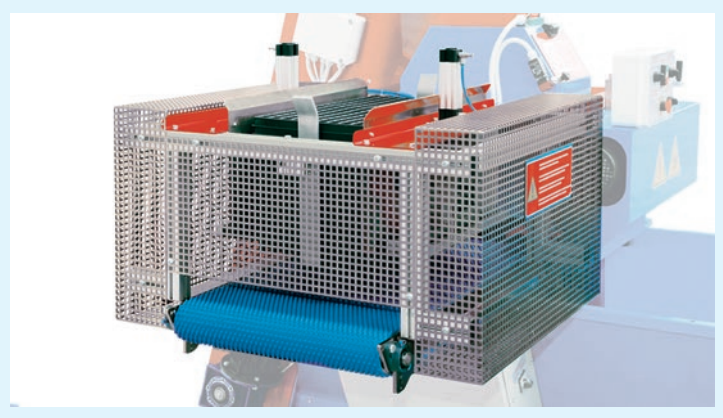

Electropneumatic **3-movements destacker**, for thermoformed trays PE - PET. 47

AVAILABLE ON:

RN12, RT12, RE14, RC65

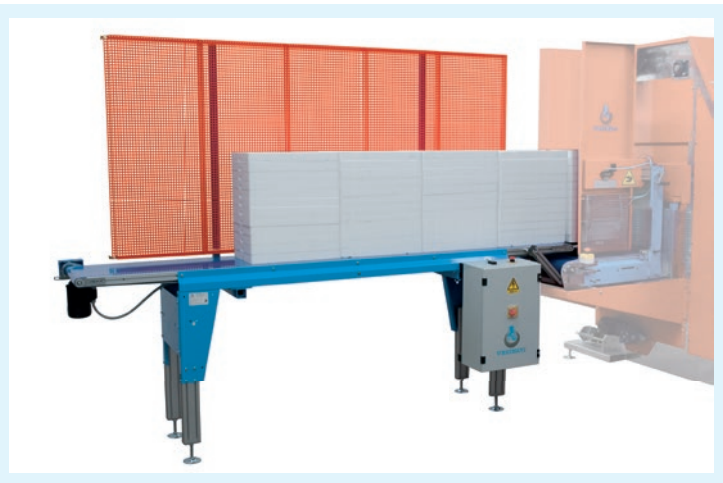

Feed belt for single trays or empty stacks for destacker
L = 3300/4300/5300/6300 mm. 50

AVAILABLE ON:

RN12, RT12, RE14, RC65



Electropneumatic **destacker with 2-movements**, adjustable with a single crank; for polystyrene trays and trays holder. 48

AVAILABLE ON:

RN12, RT12, RE14, RC65



Destacker for heavy plastic trays at injection in polypropylene PP. 49

AVAILABLE ON:

RN12, RT12, RE14, RC65

- Advancement belt with electronically **adjustable speed from 200 to 800 trays/hour**.
- **Soil compactor** with rotating movement and eccentric for **adjustable density**.
- Device **for hopper emptying** with frequency driver.
- Soil hopper extension with **additional capacity of 500 liters**.

AVAILABLE ON: RT12

- **Vibrating table** on conveyor belt.

AVAILABLE ON: RN12, RT12, RE14, RC65



These are **some of the accessories available** for our **soil tray filler**.
Our **engineering dept.** is at your disposal **to suggest the best solutions** for your needs.

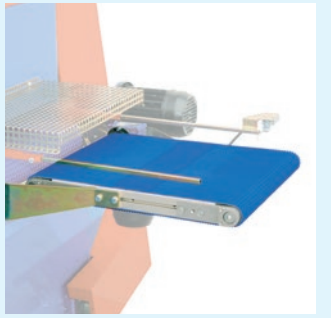

51 **Acceleration belt**
530 mm at the outlet
for the connection
to other machines.

AVAILABLE ON:
RN12, RT12, RE14, RC65

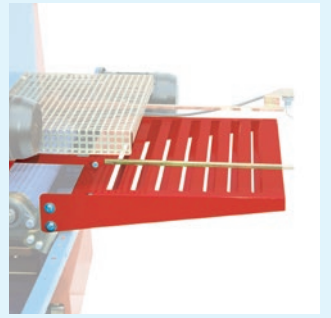

52 **Fixed table** positioned
at tray filler exit.

AVAILABLE ON:
RC65, RE14



53 **Belt system** for the
exceeding soil recycle.

AVAILABLE ON:
RC65, RE14



Quick self-centring guides adjustment system.

AVAILABLE ON:
RN12, RC65, RT12



55 **Hopper 900 liters.**

AVAILABLE ON:
RN12, RT12



56 **Hopper 1000 liters,**
complete with bulkhead
and nr. 2 turning wheels.

AVAILABLE ON:
RC65, RE14

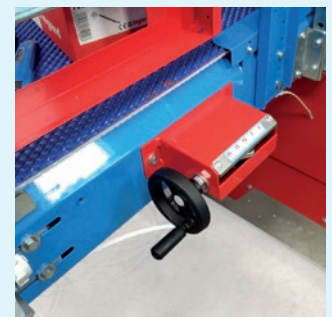

57 **Adjustment device**
for trays with legs.

AVAILABLE ON:
RN12, RC65, RE14

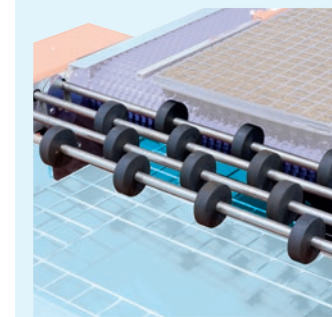

58 **Motorized exit roller,**
with nr. 4 rows.

AVAILABLE ON:
ALL TRAY FILLER



59 **Wheels kit** for handling.

AVAILABLE ON:
RC65, RE14

